

Gordon-Platt Burners have been discontinued.
For replacement parts contact Cici Boiler Rooms, Inc.



Cici Boiler Rooms, Inc.
1-800-848-8197
www.ciciboilers.com

LN Series

Installation, Operation and Start-up Instruction Manual

SUPPLEMENT FOR NO_x CONE SYSTEM

NATURAL GAS

MANUFACTURED BY JOHN ZINK COMPANY, LLC

NOTE: YOUR BURNER MAY HAVE A LETTER PREFIX OR SUFFIX ADDED TO THE MODEL DESIGNATION, HOWEVER, THIS IS FOR IDENTIFICATION PURPOSES ONLY AND DOES NOT AFFECT THE INSTRUCTIONS IN THIS MANUAL

NOTE

This manual should be used as a supplement to the standard Installation, Operation and Start-up Manuals for Models R, S or F/FL burners. The LN designation is a prefix to the standard burner model.

PRINCIPLES OF OPERATION

The LN Series of burner models uses a NO_x cone attached to the end of a standard model burner combustion head. The design of this cone causes the flue gas in the combustion chamber to recirculate back into the base of the fire. The mixing of the flue gas into the fire reduces the combustion rate and therefore the flame temperature, lowering thermal NO_x production. It is important to remember that each boiler has its own unique operating require-

ments. Two boilers of the same size with the same equipment can have different combustion properties and requirements. With different size boilers, there can be large differences in combustion properties. For these reasons, specific values or setup requirements will vary from unit to unit. Installation, operation and start-up will be the same as a standard model burner except as noted in this supplement.

TABLE OF CONTENTS

PART I - INSTALLATION INSTRUCTIONS3-4

PART II - BURNER ADJUSTMENTS5

PART III - BURNER START-UP6

PART IV - SUPPLEMENTARY DATA8

WARNINGS

If you smell gas:

1. Open windows.
2. Don't touch electrical switches.
3. Extinguish any open flame.
4. EVACUATE people from building.
5. Immediately call the gas supplier.

The use and storage of gasoline or other flammable liquids and vapors in open containers in the vicinity of this appliance is hazardous.

In accordance with OSHA standard 1910.147, all equipment, machines and processes shall be locked out prior to servicing.

If not installed, vented, operated and maintained in accordance with the manufacturer's instructions, this product could expose you to substances in fuel or from fuel combustion which can cause death or serious illness and which are known to the State of California to cause cancer, birth defects or other reproductive harm.

Improper servicing of this equipment may create a potential hazard to equipment and operators.

SERVICING MUST BE DONE ONLY BY FULLY TRAINED AND QUALIFIED PERSONNEL.

Before disconnecting or opening up a fuel line and before cleaning or replacing parts of any kind.

- Turn **OFF** the manual fuel shutoff valves including pilot gas cock, if applicable. If a multiple fuel burner, shut **OFF** all fuels.
- Turn **OFF** all electrical disconnects to the burner and any other equipment or systems electrically interlocked with the burner.

Do **NOT** use TEFLON TAPE or compounds with TEFLON content as an oil or gas pipe sealant. TEFLON can cause valves to fail creating a SAFETY HAZARD. Warranties are nullified and liability rests solely with the installer when evidence of TEFLON is found.

PART I

INSTALLATION INSTRUCTIONS

This manual has been prepared to assist in the installation, operation and start-up of your low NOx system. It is good practice to know as much as possible about a piece of equipment before trying to install and operate it. Read the contents carefully before proceeding.

NOTE

Installation requirements and instructions should always be covered in appropriate engineering drawings and specifications which detail the applicable building codes, etc. Information contained here in is to be used as a guide ONLY and not the final authority.

GENERAL

- Starting a burner with the low NOx cone system is an event which normally culminates the efforts of several different contractors, manufacturers, utility and engineering concerns, sales and factory representatives, and others.
- In order for the system to operate safely and meet its design capabilities, the interacting fuel, air, electrical, exhaust and plant heating control systems must be properly sized, selected, installed and tested. Additionally, all conditions must be such that the heat generated by the burner can be safely used or wasted without endangering personnel or equipment.
- It shall be the policy of John Zink Company, LLC that no responsibility is assumed by the company nor any of its employees for any liability or damages caused by an inadequate or unsafe condition which is the result, either directly or indirectly, of any of the improper or inadequate conditions described above. Refer to John Zink warranty statement Form 1158.
- To insure that a safe and satisfactory installation has been made, a pre-start inspection is necessary. This inspection must be performed by an individual who is thoroughly familiar with all aspects of proper boiler/burner installation and how it interfaces with overall plant operation.
- See the standard burner models instruction manual for installation inspection check list.

NOTE

This inspection should be performed before the burner start-up specialist is called in. An incomplete or inadequate installation may require additional time and effort by start-up personnel and cause an untimely and costly delay.

- The results of this inspection will often times identify corrections that must be made prior to start-up as well as point out potential or long range problems in plant operation if corrections are not made.
- Burner start-up is a serious matter and should not be viewed as a time for “crowd-gathering” by unconcerned, uninformed or unauthorized personnel. The number of persons present should be held to an absolute minimum.
- Instruction of operating and other concerned personnel should be done after the burner has successfully fired and adjusted by a qualified service agency or factory start-up specialist.

PART I

INSTALLATION INSTRUCTIONS (cont.)

Typical Installation

For forced, natural or induced draft application

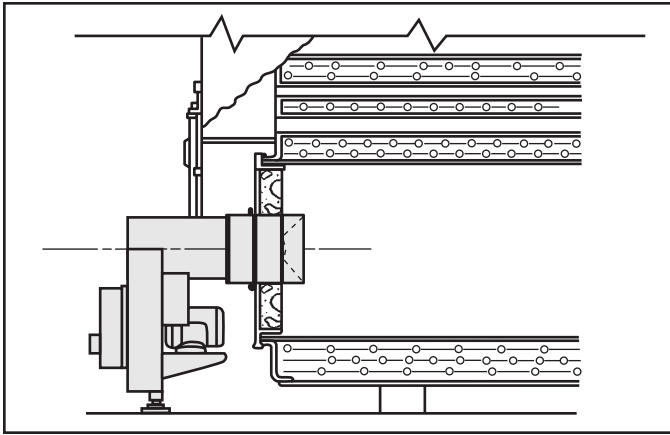

Model LNF installed in a Scotch marine type boiler

See standard burner model installation instructions for general installation requirements. The only exception to standard burner installation is **the refractory in the frontplate must be flush with the end of the combustion head and not the NOx cone.** The NOx cone must extend into the combustion chamber beyond the refractory. See figure for typical installation. Various burner nose lengths can be supplied to adapt to different frontwall thicknesses.

The LN series burners can be used to fire firetube, watertube and cast iron boilers. Frontplates and refractories are available to adapt burner to boiler or other appliance.

PARTS IDENTIFICATION

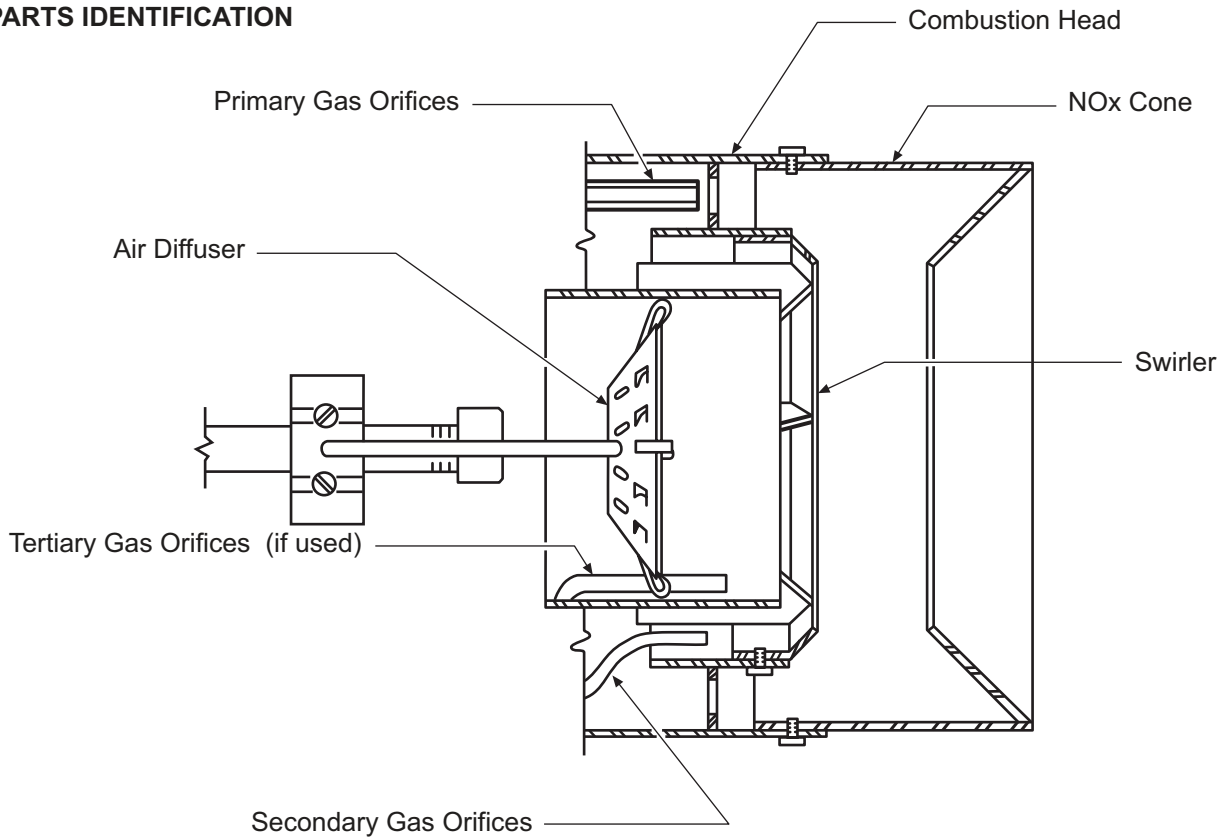

SECTION CUT OF BURNER NOSE

Typical Low NOx Combustion Head

PART II

BURNER ADJUSTMENTS

FACTORY ADJUSTMENTS - The burner is adjusted at the factory to meet “dry run” conditions. Adjustments and initial settings must be checked prior to initial light-off and settings must be verified by combustion tests.



Do not set fire visually on forced draft burners. Instruments are the only safe and reliable means to determine the proper adjustments.

AIR AND FUEL ADJUSTMENT MECHANISM - Various adjustment mechanisms control the air and fuel available for combustion. These will vary by the type of burner and the method used to control the air-fuel ratio.

See the standard burner instruction manual for the methods to adjust the various linkage systems available. The air-fuel control, drawer assembly and primary air adjustments are the same for the LN series burners and the standard burners.

PART III

BURNER START-UP

CAUTION

This manual has been prepared as a guide in burner start-up operation. It is written for the start-up specialist who is thoroughly qualified both by training and experience.

Prior to start-up of your LN series burner, review the start-up section in the appropriate standard burner manual for gas firing. Follow this start-up procedure for initial burner start-up and safety checks including the flame safeguard. In addition to the standard burner start-up procedure, there are several items that require extra care in adjustment or monitoring.

With the gas input rate established, perform a final flue gas analysis at low, high and several intermediate firing rates. The final air settings should produce a high fire O₂ between 3 to 4% with CO less than 200 ppm (or local requirements) and a NO_x level several ppm below that required. Low fire setting should produce an O₂ level between 4 and 6% with

required CO and NO_x levels. Unlike a standard model burner, increasing O₂ levels above 6% will normally cause a large increase in CO levels.

The primary air sleeve adjustment will affect all the combustion parameters. Typically, moving the primary air sleeve forward to closed position will decrease the O₂ reading, increase the CO reading and decrease the NO_x level, conversely, an increasing primary setting typically increases the O₂, decreases the CO and increases the NO_x reading. A compromise adjustments must be obtained to bring all readings to desired levels.

On a standard burner the drawer assembly position normally does not affect the combustion reading when firing gas. On the LN series the drawer assembly position can affect NO_x levels by several ppm, so adjustments should be made until the lowest NO_x levels are found and good combustion occurs.

When operating a unit for low NO_x the window of operation or “forgiveness” of adjustments becomes much narrower. Therefore additional care must be taken when adjusting or tuning the equipment.

*Gordon-Piatt Burners have been discontinued.
For replacement parts contact Cici Boiler Rooms, Inc.*



Cici Boiler Rooms, Inc.

1-800-848-8197

www.ciciboilers.com



SERVICE NOx

BOILER/BURNER TEST DATA SHEET

JOB NAME: _____

DATE: _____ *

BURNER MODEL: _____ * SERIAL NO.: _____ * BY: _____ *

AIR FLOW SWITCH CHECKED

GAS

GAS TYPE _____ BTU/C.F. _____ SP.GR. _____ BOILER TESTED _____		Pin 1	Pin 2	Pin 3	Pin 4	Pin 5	Pin 6	*
METER PRESS. _____ CORR. FACTOR _____								
ITEM	OIL #/GAL. _____ BTU/GAL. _____							
1	INPUT GAS CFH OR OIL GPH MBH							*
2	GAS ORIFICE PRIMARY P/N _____ # _____ OIL NOZZLE SECONDARY P/N _____ # _____ P/N _____ NO. REQ'D _____ GPH _____ @ _____							*
3	FUEL PRESSURE GAS _____ AT ORIFICE _____ "W. C FUEL PRESSURE GAS COMBUSTION AIR ONLY							*
4	INLET REG GAS PRESSURE							
5	OUTLET REG. GAS PRESSURE							
6	CO ₂ (INSTRUMENT USED)							*
7	O ₂ (INSTRUMENT USED)							*
8	CO OR SMOKE (INSTRUMENT USED)							*
9	GROSS STACK TEMP. _____ F ROOM TEMP. _____ F							*
10	OIL PUMP PRESSURE							
11	AIR INLET LOUVER " OPEN							*
12	SPARK PICKUP							*
13	NOx PPM INST. ECOM CORRECTED TO 3%/ UNCORR.							*
14	CHAMBER PRESSURE WITH BURNER FIRING @ HIGH							*
15	CHAMBER PRESSURE PURGE AIR ONLY							
16	DC VOLTS OR MICRO AMPS PILOT							*
17	DC VOLTS OR MICRO AMPS MAIN FLAME							*
18	DIFFUSER POSITION FROM THE END OF INNER FIRE CYL.							
19	AIR SLEEVE POSITION							*

22 MOTOR DATA @ LOW FIRE

23 MOTOR DATA @ HIGH FIRE

	L1		L2		L3	
	VLT	AMP	VLT	AMP	VLT	AMP
BLOWER						
OIL PUMP						
AIR COMP						

	L1		L2		L3	
	VLT	AMP	VLT	AMP	VLT	AMP
BLOWER						
OIL PUMP						
AIR COMP						

NOTE

EQUIPMENT WILL NOT BE COVERED UNDER WARRANTY UNLESS THIS FORM IS RETURNED TO MANUFACTURER. ITEMS MARKED WITH (*) MUST BE FILLED OUT. IF BURNER IS EQUIPPED WITH CHARACTERIZED LINKAGE THEN INFORMATION AT ALL PIN POSITIONS WILL BE REQUIRED.