



## Air Pressure Sensing Switch with Adjustable Set Point Range



### General Description & Operation

The plated housing contains a diaphragm, a calibration spring and a snap-acting SPDT switch.

The sample connections located on each side of the diaphragm accept .25" OD metallic tubing via the integral compression ferrule and nut.

An enclosure cover guards against accidental contact with the live switch terminal screws and the set point adjusting screw. The enclosure cover will accept a .5" conduit connection.

### Mounting (see Figure 1)

Select a mounting location which is free

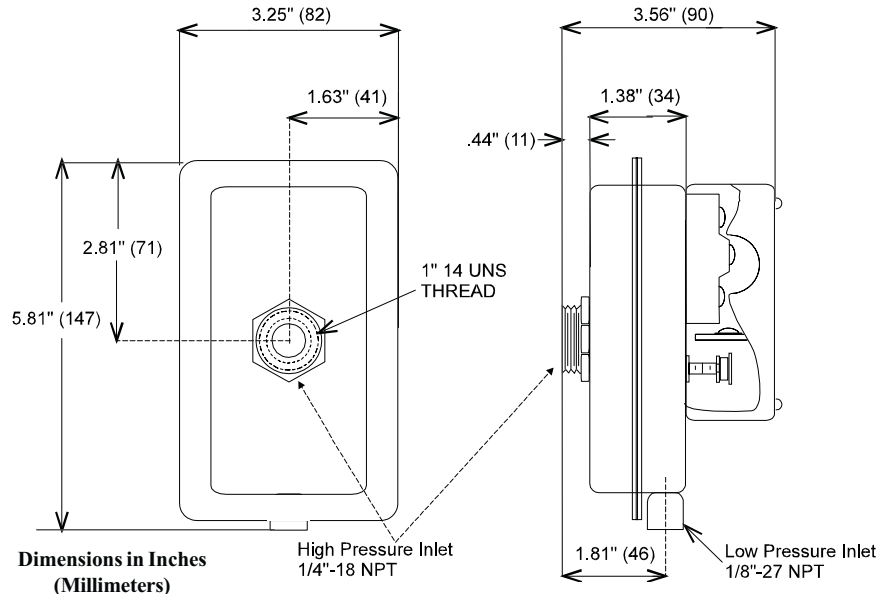
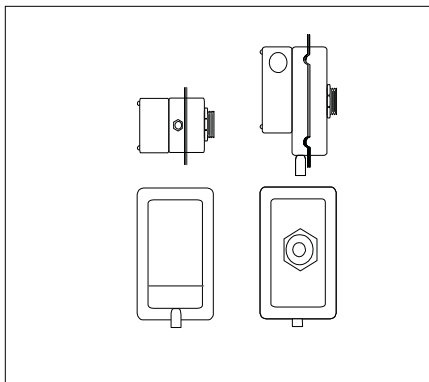

Dimensions in Inches (Millimeters)  
High Pressure Inlet 1/4"-18 NPT

from vibration. The AFS-A must be mounted with the diaphragm in any vertical plane in order to obtain the lowest specified operating set point. Avoid mounting with the sample line connections in the "up" position. Surface-mount the switch to a flange via the 1-inch, -14 externally threaded connector with pal nut. This connector is also internally threaded (1/4" - 18 NPT) for rigid mounting to a pipe nipple.

### Air Sampling Connection (see Figure 2)

The AFS-A is equipped with a 1/4" - 18 NPT female connector ("H" in Figure 2) and a 1/8" - 27 NPT female connector ("L" in Figure 2). For sample lines of up to 10 feet, 1/8" pipe is acceptable. For lines up to 20 feet, use 1/4" pipe. For lines up to 60 feet, use 1/2" pipe. For each right angle bend, add 4' to the computed sample line length to determine correct pipe size.

Refer to Figure 2 to identify the high pressure inlet (H) and the low pressure inlet (L). Select one of the five application options listed below, and connect the sample lines as recommended.

**POSITIVE PRESSURE ONLY:** Connect the sample line to inlet H; inlet L

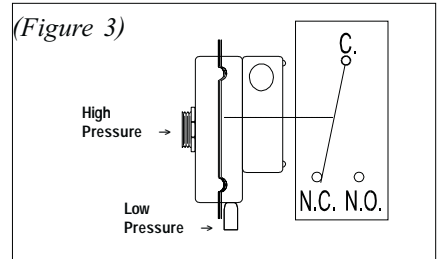
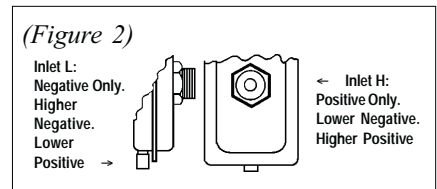

(Figure 4)

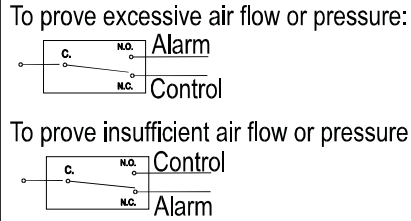

remains open to the atmosphere.

**NEGATIVE PRESSURE ONLY:** Connect the sample line to inlet L; inlet H remains open to the atmosphere.

**TWO NEGATIVE SAMPLES:** Connect the higher negative sample to inlet L. Connect the lower negative sample to inlet H.

**TWO POSITIVE SAMPLES:** Connect the higher positive sample to inlet H. Connect the lower positive sample to inlet L.

**ONE POSITIVE AND ONE NEGATIVE SAMPLE:** Connect the positive sample to inlet H. Connect the negative sample to inlet L.

### Electrical Connections (see Figure 3)

Before pressure is applied to the diaphragm, the switch contacts will be in the normally closed (NC) position.

The snap switch has screw top terminals with cup washers. Wire alarm and control applications as shown in Figure 4.

### Field Adjustment

The adjustment range of an AFS-A Air Switch is 0.05 to 12.0" w.c.,  $\pm 0.02$ " w.c. To adjust the set point:

Turn the adjusting screw counterclockwise until motion has stopped. Next, turn the adjusting screw 4 complete turns in a clockwise direction to engage the calibration spring. From this point, the next ten turns will be used for the actual calibration. **Each full turn represents approximately 1.2" w.c.**

**Please note:** To properly calibrate a Air Switch, a digital manometer or other measuring device should be used to confirm the actual set point.

### Specifications

#### Model AFS-A Air Flow Switch

**Mounting Position:** Mount with the diaphragm in any vertical plane.

**Set Point Range:**

0.05  $\pm$  0.02" w.c. to 12.0" w.c. (0.508 mm w.c. to 304.8 mm w.c.) (0 to 0.43 psi).

**Approximate Switching Differential:**

Progressive; increases from 0.02  $\pm$  0.01" w.c. at minimum set point to approximately 0.8" w.c. at maximum set point.

**Measured Media:** Air, or combustion by-products that will not degrade silicon.

**Maximum Pressure:** 1/2 psi (0.03 bar)

**Operating Temperature Range:**

-40F to 180F (-40 to 82C)

**Life:** 100,000 cycles minimum at 1/2 psi maximum pressure each cycle and at maximum rated electrical load.

**Electrical Rating:**

300 VA pilot duty at 115 to 277 VAC, 15 amps noninductive to 277 VAC, 60 Hz.

**Contact Arrangement:** SPDT

**Electrical Connections:** Screw-type terminals with cup washers.

**Conduit Opening:** 7/8" diameter opening accepts 1/2" conduit.

**Sample Line Connectors:** 1/4" - 18 NPT female (high pressure inlet) 1/8" - 27 NPT female (low pressure inlet)

**Sample Line Connections:** Connectors will accept 1/4" OD rigid or semi-rigid tubing.

**Approval:** UL, FM, CSA

**Shipping Weight:** 2 lbs.

AFS-A Sensing Switches are manufactured by Cleveland Controls Div. of UniControl Inc.

#### Pressure Conversion Table

1" H<sub>2</sub>O = .0361 lbs./sq. in. or .0735 in. mercury

1" Hg. = .491 lbs./sq. in. or 13.6 in. water

1 psi = 27.7 in. water or 2.036 in. mercury

#### Accessories

- Sample line probes.
- Orifice plugs (pulsation dampeners).

